



Ohio Edison • The Illuminating Company • Toledo Edison
Met-Ed • Penelec • Penn Power • Jersey Central Power & Light
West Penn Power • Mon Power • Potomac Edison

Meter Socket Specification Update

Temporary waiver of the side-wire (side bus) requirement for meter sockets installed on UG services. Effective 10/25/21.



Meter Engineering Group

FirstEnergy Self-Contained Meter Socket Specification Change

Side-wire requirement for OH/UG sockets

TEMPORARY WAIVER

FirstEnergy's Customer Guide for Electric Service booklets (OH, PA, MD, NJ, WV) presently state that side-wired sockets are required (preferred in Ohio) for UG service connections. This side-wire requirement is being temporarily waived at this time to allow non-side-wired sockets to be used on UG service connections. It is important that the following installation practices and example connections be followed when non-side-wired sockets are installed for UG service.

Non-side-wired sockets used for UG service need to provide adequate space for the line-side conductors to be formed so that slack exists in each conductor after terminations are complete. This slack is to allow conductor movement downward should some UG settling occur, without putting excess tension on the line-side terminations, jaws or other socket components.

Below are three examples of non-side-wired socket styles that will now be accepted for UG service. We will now allow these socket styles to be utilized if they provide sufficient conductor routing space to accommodate excess slack when terminating line-side conductors.

Important enclosure height requirements for non-side-wired sockets used on UG service:

- 200-amp socket minimum height is 19". Offset socket minimum height is 15".
- 320-amp meter socket minimum height is 26".

These enclosure height dimensions will help to ensure space exists for conductor slack.



Below are six examples of wire forming and routing within non-side-wired UG sockets. The top three (green check) demonstrate proper conductor forming. The bottom three examples (red X) demonstrate possible errors that lessen or eliminate the necessary slack conductor. Socket installations having insufficient line-side conductor slack will **not be accepted or put into service**.

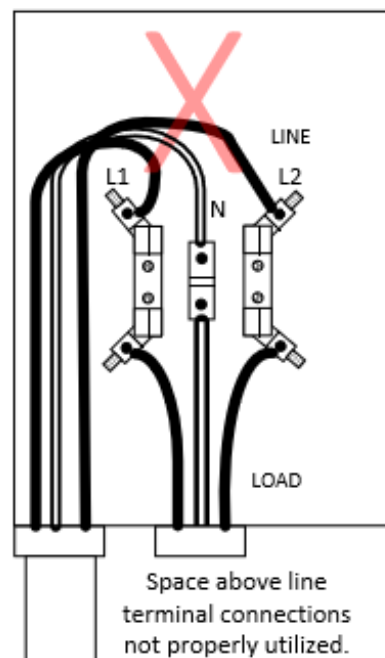
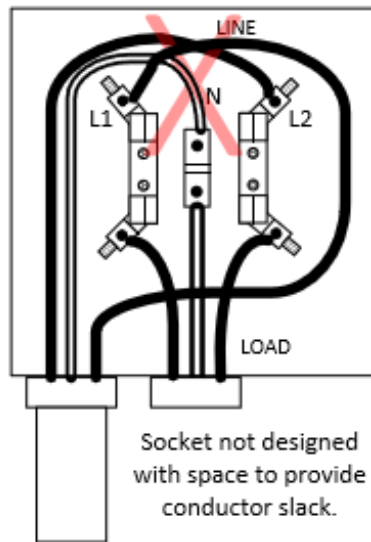
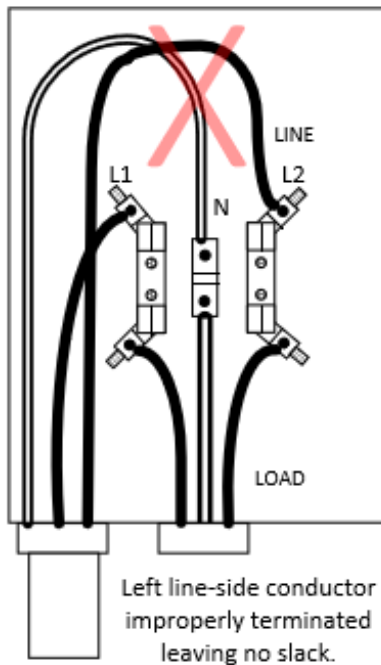
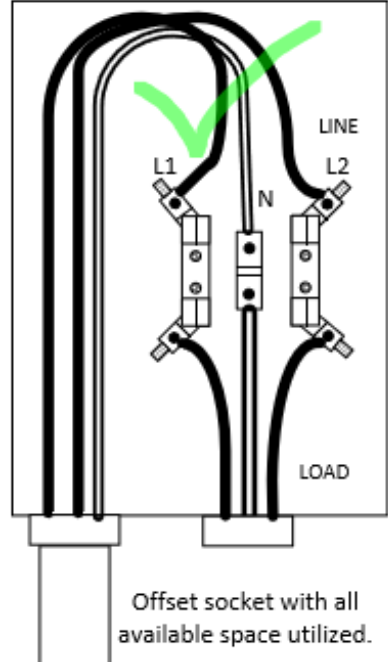
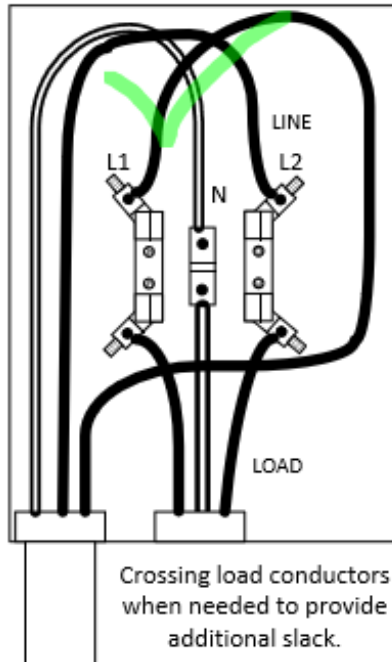
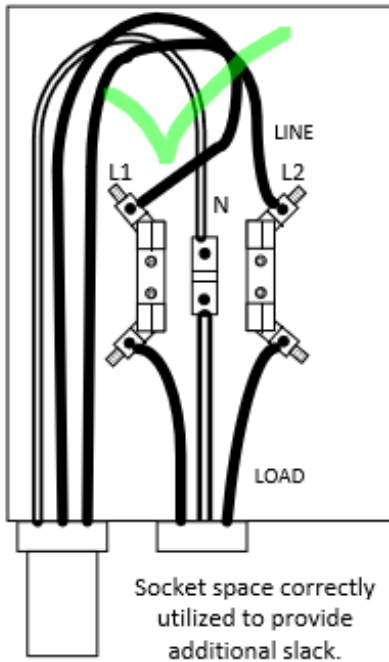

NOTES:

- Before forming and terminating line-side conductors at socket, grasp the conductors and push them downward into the conduit. This will typically result in producing additional slack conductor within the conduit itself.
- Not all meter sockets sold as OH/UG may provide for the slack conductor space as described in the above examples. When unsure, seek utility approval of the specific socket model before use.

Other than this temporary waiver of the side-wire requirement, all other meter socket and installation requirements detailed within the OH, WV, PA, MD, and NJ Customer Guide for Electric Service (CGES) booklets remain in effect. Refer to Exhibit 8 within your state's CGES booklet for information regarding important installation components and requirements such as conduit strap locations, use of slip joints, trench preparation, etc.

NOTE: This temporary side-wire waiver is **not** referenced within the current CGES booklets. This waiver only allows for non-side-wired sockets to be utilized when sufficient conductor slack can be achieved when making up line-side terminations.

Below are the FirstEnergy descriptions for three (3) non-side-wired sockets having the minimum space needed to allow for sufficient line-side conductor slack on UG connections.

Socket Meter 200A 4/5 Jaw OH/UG:

SOCKET, METER, 200 AMPERE, 4 TERMINAL W/PROVISION FOR 5TH TERMINAL, SUITABLE FOR UNDERGROUND AND OVERHEAD SERVICE, RINGLESS, #2-350 kcmil CONNECTIONS, NON-SIDE WIRED, UL APPROVED, HORN-TYPE BYPASS OR LEVER BYPASS, MINIMUM HEIGHT OF SOCKET 19", OFFSET SOCKET MINIMUM HEIGHT 15"

Socket Meter 320A 4/5 Jaw OH/UG:

SOCKET, METER, 320 AMPERE, 4 TERMINAL W/PROVISION FOR 5TH TERMINAL, SUITABLE FOR UNDERGROUND AND OVERHEAD SERVICE, RINGLESS, #4-600 kcmil LINE SIDE CONNECTIONS, NON-SIDE WIRED, UL APPROVED, LEVER-TYPE BYPASS, MINIMUM HEIGHT OF SOCKET 26"

SOCKET METER 320A 7 TERM OH/UG:

SOCKET, METER, 320 AMPERE, 7 TERMINAL, SUITABLE FOR UNDERGROUND AND OVERHEAD SERVICE, RINGLESS, #4-600 kcmil LINE SIDE CONNECTIONS, NON-SIDE WIRED, UL APPROVED, LEVER-TYPE BYPASS, MINIMUM HEIGHT OF SOCKET 26"